

BY54 Series

Brushless

BY54(インナーロータイプ Inner Rotor Type) ※ドライバ付 with Driving Circuit

ドライバ：①外部制御 (1-5V) ②外部制御 (PWM)
③速度制御 (CLKin) ④ドライバ回路なしも対応可能

Driving Circuit：①Open loop(1-5V) ②Open loop(PWM)
③Speed Control(CLKin) ④Variant without driving circuit possible.

寸法図 Dimension

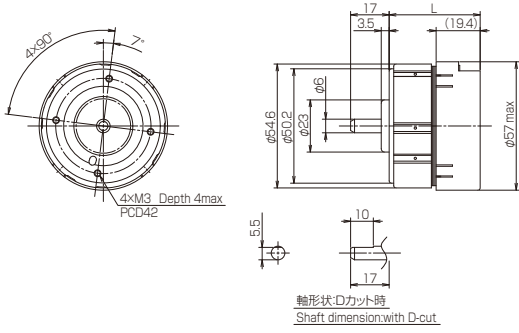

特性図 T-N-I curve

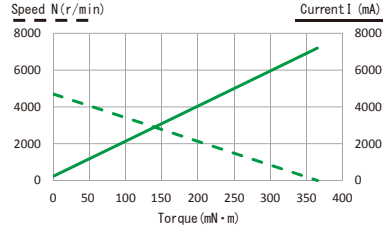

型番 Model	定格電圧 Rated Voltage V	定格出力 Rated Output W	定格トルク Rated Torque mN·m (gf·cm)	定格回転数 Rated Speed r/min	定格電流 Rated Current A	軸径 Shaft Dia mm	無負荷回転数 No Load Speed r/min	無負荷電流 No Load Current A	起動トルク Starting Torque mN·m (gf·cm)	起動電流 Starting Current A	トルク定数 Torque Constant mN·m/A (gf·cm/A)	端子間抵抗 Terminal Resistance (winding) Ω	インダクタンス Inductance mH	イナーシャ Moment of Inertia g·cm ²	機械的時定数 Mechanical Time Constant ms	熱抵抗 Thermal Resistance K/W	L寸 Length mm	質量 Weight g
BY54	24	33.40	90.2 (920)	3540	2.00	6.0	4700	0.23	—	—	52.96 (540)	1.0	1.76	52.00	8.6	5.4	41.0	330.0